

Planter Assembly Instructions

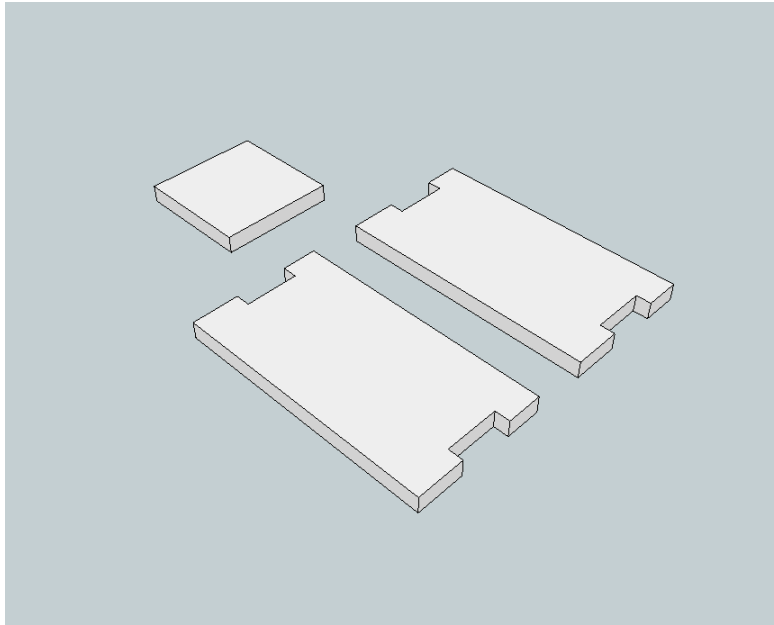

1. Each kit should contain 3 Cedar wooden parts (Some may already be pre-cut and contain 5 parts).
 - a. One 5" square bottom
 - b. Two 11" x 5 3/4" side pieces (or four 5 1/2" x 5 3/4" sides)

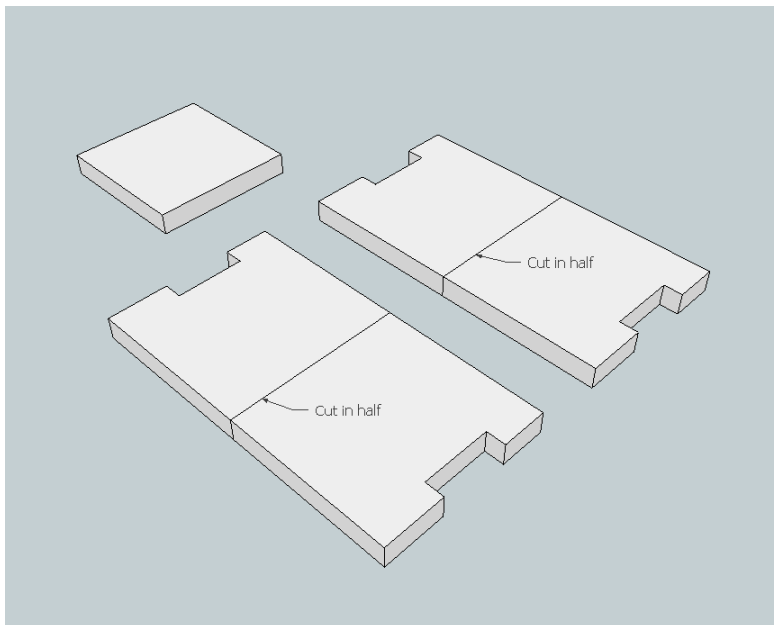

2. Cut the long parts in half with a saw.

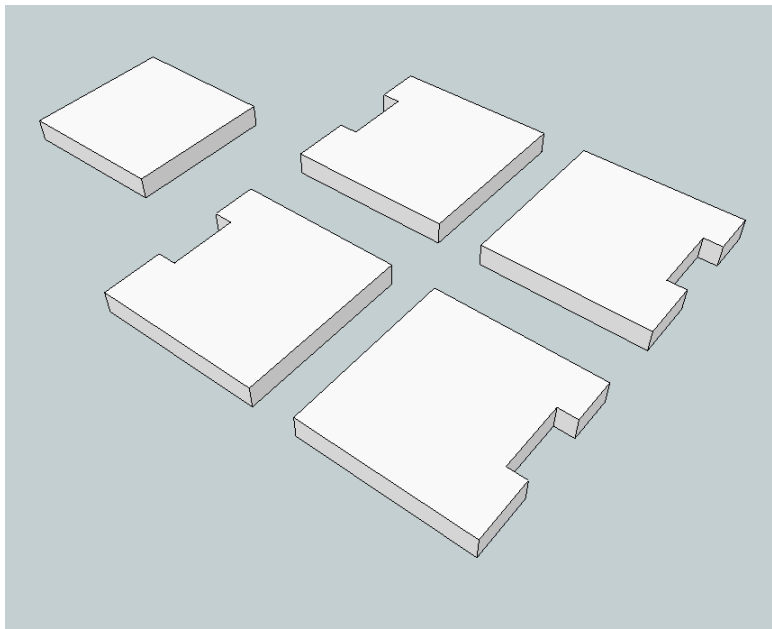

3. Each side is notched at the bottom. There is a wide leg and a thin leg.

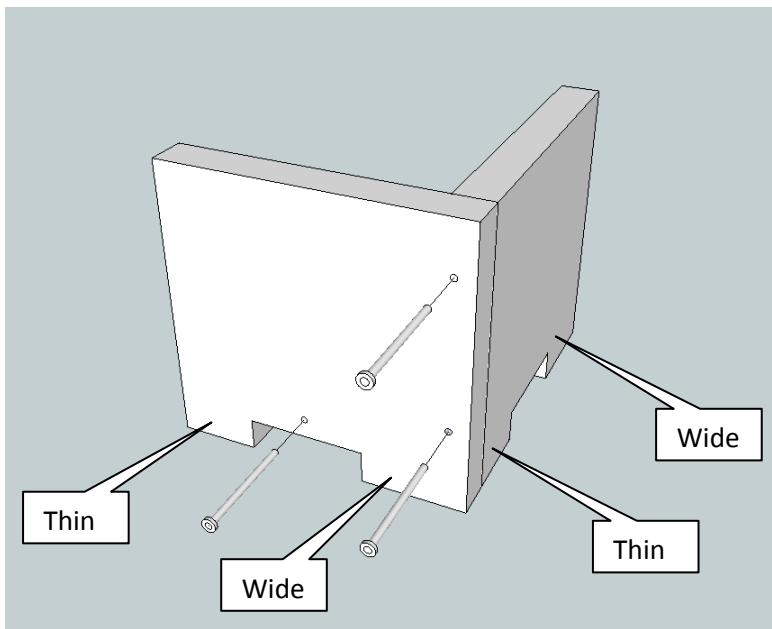

4. Nail the side with the wide leg to a side with a thin leg. Also nail the bottom piece to the sides.

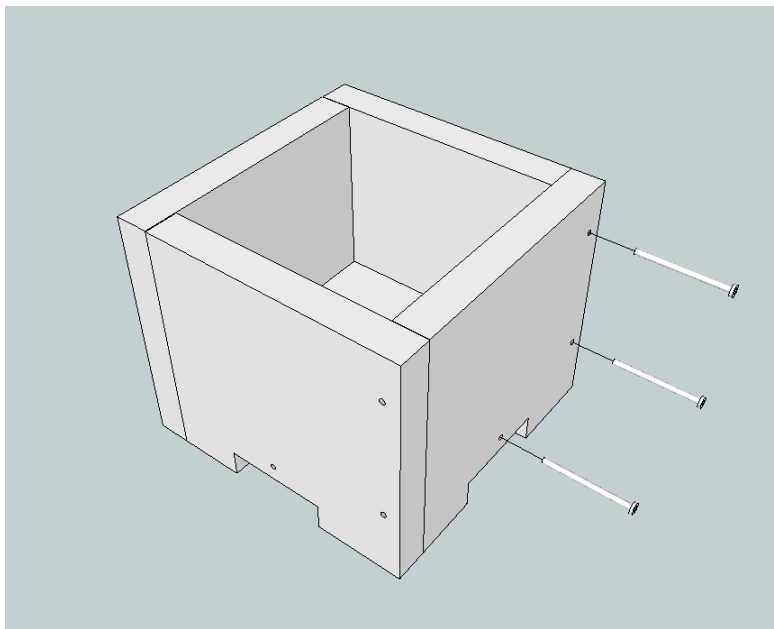
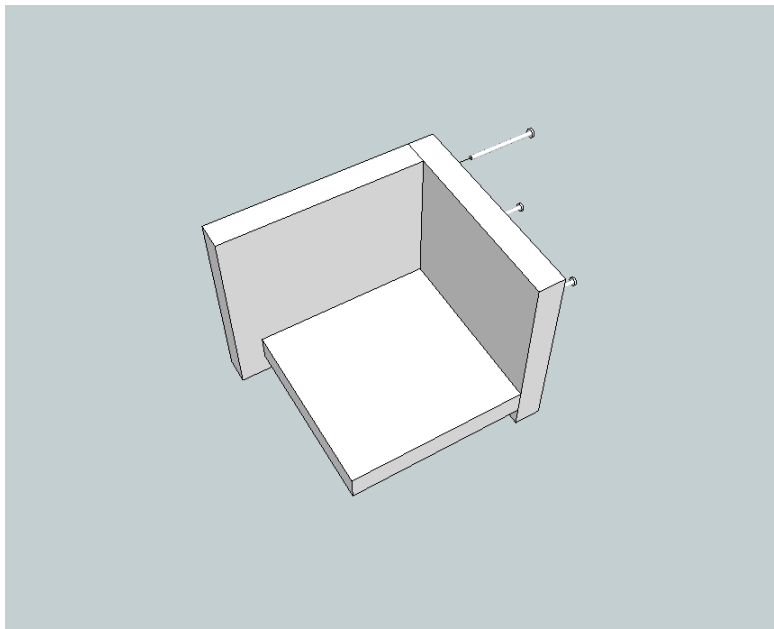

5. Use 3 nails per side, two to hold the sides and one to hold the bottom. Notice how each side overlaps the next side while capturing the bottom piece in the middle.